

# Energy Management Power Analyzer with plug-in Output Modules Type WM22-DIN

CARLO GAVAZZI



- Front dimensions: 9 DIN modules
- Analogue output by means of optional module (20mA or 10VDC)
- RS 422/485 Serial port by means of optional module
- Alarm output by means of optional module
- Dual pulse output by means of optional module
- Control of phase asymmetry

## Product description

Three-phase power analyzer with built-in configuration key-pad; Particularly indicated for the analysis of main, secondary and energy metering electrical variables. Housing for DIN-rail or wall-mounting, IP40 (front) protection degree. Completely sealable housing. In case of direct connection up to 90A, the measuring input terminals are suitable for cables with a cross-section

area from 6 to 35 mm<sup>2</sup>. The special design of the instrument's housing allows to add at any time the interface modules, even when the instrument is already installed.

The following modules are available:

- for all versions: pulses output;
- only for the versions with auxiliary power supply: analogue output, RS485 port or alarm output.

- Class 0.5 (current/voltage)
- Three-phase power analyzer
- Back-lighted LCD
- 4 x 3<sup>1</sup>/<sub>2</sub> DGT instantaneous variables read out
- 7<sup>1</sup>/<sub>2</sub> DGT energy read-out
- Measurements of system and phase variables: W, Wdmd, var, VA, VAdmd, PF (cosφ), V, A, Hz, THD-A, THD-V
- Measurements of total energies: kWh, kvarh
- Measurements of partial energies: kWh, kvarh
- Energy measurements according to EN61036 and EN61268
- TRMS measurements of distorted wave forms (voltages/currents)
- Two basic models: direct connection 20(90)AAC, CT 5(10)AAC and VT connection
- Maximum value indication of W dmd and VA dmd (only 5A version); maximum value indication of A (only 90A version)
- Self power supply (available for some models only) or auxiliary power supply: 24V, 48V, 115V, 230V, 50-60Hz; 18 to 60VDC, 77 to 143VDC
- Degree of protection (front): IP 40

## How to order **WM22-DIN AV5 3 X X XX**

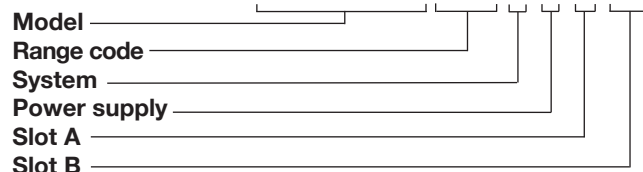

### Important note:

- The models from AV0 to AV7 can be equipped with any type of available modules (slot A and B).
- The models AV8 and AV9 can be equipped only with the "O" and "R" type modules.
- The AV8 and AV9 models can measure all the parameters even if the three phase system being connected is missing one phase.
- The AV2 model is suitable only for three-phase unbalanced system without neutral.

## Type selection

Range Code	Power supply	Slot A (retransmission)	Slot B (retransmission)
<b>Auxiliary Power Supply:</b>	<b>For all versions</b>	<b>X:</b> None	<b>Only with A-B-C-D-4 power supply</b>
<b>AV0:</b> 208V <sub>L-L</sub> /20(90)AAC [3]	<b>A:</b> 24VAC	<b>O:</b> AO2900 module	<b>XX:</b> None
<b>AV1:</b> 400V <sub>L-L</sub> /20(90)AAC [1]	-15+10%, 50-60Hz	Dual open collector output	<b>A1:</b> AO2920 module
<b>AV3:</b> 660V <sub>L-L</sub> /20(90)AAC [2]	<b>B:</b> 48VAC	Three operating modes:	0-20mADC
<b>AV4:</b> 208V <sub>L-L</sub> /5(10)AAC [3]	-15+10%, 50-60Hz	• two pulse outputs (kWh and kvarh);	analogue output
<b>AV5:</b> 400V <sub>L-L</sub> /5(10)AAC [1]	<b>C:</b> 115VAC	• one alarm output	<b>V1:</b> AO2921 module
<b>AV6:</b> 100V <sub>L-L</sub> /5(10)AAC [3]	-15+10%, 50-60Hz	and one pulse output (kWh or kvarh)	0-10VDC
<b>AV7:</b> 660V <sub>L-L</sub> /5(10)AAC [2]	<b>D:</b> 230VAC	• one output which is remotely controlled by a serial port	analogue output
<b>Self Power Supply:</b>	-15+10%, 50-60Hz	and one pulse output (kWh or kvarh)	<b>S0:</b> AR2950 module
<b>AV2:</b> 220V <sub>L-L</sub> /20(90)AAC [4]	<b>4:</b> 18 to 60VDC		RS422/485
<b>AV8:</b> 208V <sub>L-L</sub> /20(90)AAC [1]	<b>5:</b> 77 to 143VDC	<b>R:</b> AO2910 module.	serial port
<b>AV9:</b> 400V <sub>L-L</sub> /20(90)AAC [1]	<b>AV2, AV8 and AV9 only</b>	One relay output + one open collector output.	
<b>System</b>	<b>X:</b> Self Power Supply	Operation modes like module AO2900.	
<b>3:</b> Three-phase, unbalanced load with or without neutral	400V <sub>L-L</sub> (-20+15%, 50-60Hz)		
	208V <sub>L-L</sub> (-20+15%, 50-60Hz)		
	220V <sub>L-L</sub> (-10+15%, 50-60Hz)		

[1] Un: -20+15% [2] Un: -30+15% [3] Un: -20+20% [4] Un: -10 +15%

## Input specifications

<b>Number of inputs</b>		<b>Additional errors</b>	Acc. to EN61036, EN61268
Current	3	Wave form	<1% (3 <sup>rd</sup> harmonic: 10%)
Voltage	4	Voltage asymmetry	< 0.5% (referred to Un)
<b>Accuracy</b> (display, RS485)	Ib: 5A, I <sub>max</sub> : 10A Ib: 20A, I <sub>max</sub> : 90A Un: see previous page "Range code"	Magnetic induction	0 (up to 0.5 mT)
Current	from 0.003Ib to 0.2Ib: ±(0.5% RDG + 3DGT) from 0.2Ib to I <sub>max</sub> : ±(0.5% RDG + 1DGT)	HF Electromagnetic fields	< 1%
Voltage	in the range Un: ±(0,5% RDG + 1DGT)	Operation of accessories	0
Frequency	±0.1% RDG (50 to 60 Hz)	<b>Temperature drift</b>	≤ 200ppm/°C
Active power (@ 25°C ± 5°C, R.H. ≤ 90%)	±(1% RDG + 1DGT). PF 1, 0.1Ib to I <sub>max</sub> , in the Un range; PF 0.5L, PF 0.8C, 0.2Ib to I <sub>max</sub> , in the Un range	<b>Sampling rate</b>	1000 samplings/s @ 50Hz
Reactive power (@ 25°C ± 5°C, R.H. ≤ 90%)	±(2% RDG + 1DGT). sinφ 1, 0.05Ib to I <sub>max</sub> , in the Un range; sinφ 0.5L, sinφ 0.5C, 0.1Ib to I <sub>max</sub> , in the Un range	<b>Display</b>	Type Instantan. variables read-out Energies
Apparent power (@ 25°C ± 5°C, R.H. ≤ 90%)	±(1% RDG + 1DGT). PF 1, 0.1Ib to I <sub>max</sub> , in the Un range		Back-lighted LCD 4x3 <sup>1</sup> / <sub>2</sub> DGT Total: 1x7 <sup>1</sup> / <sub>2</sub> DGT Partial: 1x7 <sup>1</sup> / <sub>2</sub> DGT
Energies (@ 25°C ± 5°C, R.H. ≤ 90%)	Class 1 acc. to EN61036 Class 2 acc. to EN61268 Ib: 5A, I <sub>max</sub> : 10A 0.1Ib: 500mA, Start up current: 20mA Un: see table "range code" Ib: 20A, I <sub>max</sub> : 90A 0.1Ib: 2A, Start up current: 80mA Un: see table "range code"	<b>Max. and Min. indication</b>	Max. 1999 (19999999), Min. 0
Harmonic distortion (@ 25°C ± 5°C, R.H. ≤ 90%)	±3% f.s. (f.s.: 100%) up to the 7 <sup>th</sup> harmonic; Un: see table "range code"	<b>Measurements</b>	Current, voltage, power, energy, power factor, frequen- cy, harmonic distortion (see display specs). TRMS measurements of distorted wave forms. Direct
Ib 5A	I <sub>min</sub> : 500mA; I <sub>max</sub> : 15Ap;	Coupling type	
Ib 20A	I <sub>min</sub> : 2A; I <sub>max</sub> : 127Ap;	<b>Crest factor</b>	
		Ib 5A	≤3 (15A max. peak)
		Ib 20A	≤6 (127A max. peak)
		<b>Current overload</b>	
		5(10) A, for 10ms	300 A max, @ 50Hz
		5(10) A, for 500ms	200 A max, @ 50Hz
		5(10) A, permanent	10A, @ 50Hz
		20(90) A, for 10ms	2700A max, @ 50Hz
		20(90) A, permanent	90A, @ 50Hz
		<b>Voltage overload</b>	
		Permanent	1.2 Un
		For 1s	2 Un
		<b>Input impedance</b>	
		400V <sub>L-L</sub> (AV1-AV5-AV9)	> 720KΩ
		208V <sub>L-L</sub> (AV0-AV4-AV8-AV2)	> 720KΩ
		660V <sub>L-L</sub> (AV3-AV7)	> 1.97MΩ
		100V <sub>L-L</sub> (AV6)	> 400KΩ
		5(10) A (AV4-AV5-AV6-AV7)	< 0.3VA
		20(90) A (AV0-AV1-AV3-AV8-AV9)	< 4VA
		20(90) A (AV2)	< 4VA
		<b>Frequency</b>	50 to 60 Hz

## Interface module specifications

<b>Analogue outputs</b> (on request)			the following ranges: 0 and 20mADC, 0 and 10VDC
Number of outputs	1	Response time	
Range	0 to 20 mADC (AO2920 module slot B, only for versions with auxiliary power supply) 0 to 10VDC (AO2921 module slot B, only for versions with auxiliary power supply)	System variables	V, W, VA, var, PF (cosφ)
Accuracy	±0.5% F.S.	FFT off, filter off	900ms
Temperature drift	≤ 300 ppm/°C	FFT on, filter on	1.4s
Scaling factor	Programmable within the whole range of retransmission; it allows the retransmission of all the values included in	variables	THD-V, THD-A
		Filter off	3s
		Ripple	≤ 1% according to IEC 60688-1, EN 60688-1
		Load	≤ 500 Ω
		20 mADC	≥ 10 kΩ
		10 VDC	By means of optocouplers, 2000 V <sub>RMS</sub> between output and measuring input
		Insulation	

## Interface module specifications (cont.)

	2000 V <sub>RMS</sub> between output and power supply input		
<b>RS422/RS485</b> (on request)	AR2950 module	Insulation	According to DIN43864 By means of optocouplers, 2000 V <sub>RMS</sub> outputs to measuring inputs, 2000 V <sub>RMS</sub> output to supply input. Insulation between the two outputs: functional
Type	Multidrop bidirectional (static and and dynamic variables)		
Connections	2 or 4 wires, max. distance 1200m, termination directly on the module	Alarm output	
Addresses	255, selectable by key-pad	Number of outputs	1
Protocol	MODBUS/JBUS	Alarm type	Up alarm, down alarm phase asymmetry, phase loss.
Data (bidirectional)		Setpoint adjustment	0 to 100% of the electrical scale
Dynamic (reading only)	Phase and system variables: see table "Display pages"	Hysteresis	0 to 100% of the electrical scale
Static (writing only)	All the programming data, reset of energy, activation of static output.	On-time delay	0 to 255 seconds
Data format	Stored energy (EEPROM) max. 19.999.999 kWh/kvarh	Response time	
Baud-rate	1 start bit, 8 data bit, no parity, 1 stop bit	system variables	V, W, VA, var, PF (cosφ)
Insulation	9600 bit/s	FFT off, filter off	700ms
	By means of optocouplers, 2000 V <sub>RMS</sub> output to measuring inputs	FFT on, filter on	1.2s
	2000 V <sub>RMS</sub> output to supply input	variables	THD-V, THD-A
		Filter off	3s
		Output type	Open collector (transistor NPN) V <sub>ON</sub> 1.2 VDC / max. 100 mA V <sub>OFF</sub> 30 VDC max.
<b>Digital outputs</b> (on request)		Insulation	By means of optocouplers, 2000 V <sub>RMS</sub> output to measuring input, 2000 V <sub>RMS</sub> output to supply input. Insulation between the two outputs: functional
AO2900 module	To be used as alarm, energy retransmission, or remote static outputs.	AO2910 module	Relay + open collector output. Working mode like AO2900.
	Three working modes are selectable:	Pulse output	One static output+one relay output, other characteristics like AO2900.
	• two pulse outputs (kWh and kvarh);	Alarm output	Only relay output, other characteristics like AO2900.
	• one alarm output and one pulse output (kWh or kvarh)	Output type	Static type like module AO2900;
	• one output remotely controlled by means of the serial port and one pulse output (kWh or kvarh)	Insulation	Relay type: SPDT, AC1, AC15: 1AAC @250VAC
Pulse outputs			By means of optocouplers, 2000 V <sub>RMS</sub> outputs to measuring inputs, 2000 V <sub>RMS</sub> output to supply input. Insulation between the two outputs: 2000 V <sub>RMS</sub>
Number of outputs	2		
Number of pulses	From 0.01 to 100 pulses programmable according to the selected CT and VT ratios		
Output type	Open collector (transistor NPN) V <sub>ON</sub> 1.2 VDC / max. 100 mA V <sub>OFF</sub> 30 VDC max.		
Pulse duration	220 ms (ON), ≥ 220 ms (OFF)		

## Software functions

<b>Password</b>	Numeric code of max. 3 digits 2 protection levels of the programming data Password "0", no protection Password from 1 to 1000, all data are protected	<b>Electrical range</b>	Programmable within the whole measuring range.
1 <sup>st</sup> level 2 <sup>nd</sup> level		<b>Filter</b>	
<b>System selection</b>	Three-phase with neutral Three-phase without neutral	Filter operating range	0 to 99.9% of the input electrical scale.
<b>Transformer ratio</b>		Filter coefficient	1 to 16
CT	1 to 5000	Filter action	Alarm, analogue and serial output (fundamental variables: V, A, W and their derived ones).
VT	1.0 to 199.9 and 200 to 1999 Note: The CT ratio* VT ratio must never exceed the value 5000. The current measuring inputs can manage CT's with a secondary of 1A and 5A (the accuracy always refer to 5A)	<b>Display</b>	
<b>Scaling factor</b>		System variables	Up to 4 variables per page Page 1: W-var-PF (cosφ) Page 2: W dmd - VA dmd - Hz Page 3: THD-V Page 4: THD-A Page 5: kWh total Page 6: kvarh total Page 7: kWh partial Page 8: kvarh partial Page 9: V <sub>L-N</sub> Page 10: A Page 11a: A <sub>MAX</sub> Page 11b: W dmd <sub>MAX</sub> VA dmd <sub>MAX</sub> Page 12: W Page 13: VA Page 14: var Page 15: PF (cosφ)
Operating mode	Compression/expansion of the measuring range to be connected to the analogue output.	Single phase variables	
		System variables	
		Single phase variables	
		20(90) A 5(10) A	

## Supply specifications

<b>Self supplied version</b>	400V <sub>L-L</sub> -20% +15%, 50-60Hz 208V <sub>L-L</sub> -20% +15%, 50-60Hz 220V <sub>L-L</sub> -10% +15%, 50-60Hz	115VAC -15 +10%, 50-60Hz 48VAC -15 +10%, 50-60Hz 24VAC -15 +10%, 50-60Hz
<b>Auxiliary power supply</b>	230VAC -15 +10%, 50-60Hz	18 to 60VDC 77 to 143VDC
		<b>Energy consumption</b>
		≤ 7VA

## General Specifications

<b>Operating temperature</b>	0 to +55°C (R.H. < 90% non-condensing 40°C)	<b>Pulse voltage (1.2/50μs)</b>	8kV (EN61000-4-5)
<b>Storage temperature</b>	-20 to +60°C (R.H. < 90% non-condensing 40°C)	<b>Standards</b>	
<b>Installation category</b>	Cat. III (IEC 664)	Safety	IEC664-1
<b>Insulation</b>	2000 V <sub>RMS</sub> between all inputs / outputs to earth	Metrology	Energy measurements: EN61036, EN61268. DIN43864
<b>Dielectric strength</b>	4000 V <sub>RMS</sub> for 1 minute	Pulse output	
<b>Noise rejection</b>		<b>Approvals</b>	CE
CMRR	100 dB, 48 to 62 Hz	<b>Connections 5(10) A</b>	Screw-type, 4 mm <sup>2</sup>
<b>EMC</b>		Cable cross-section area	
Burst	4kV/level 4 (EN61000-4-4)	<b>Connections 20(90) A</b>	Screw-type, 6 mm <sup>2</sup> / 35 mm <sup>2</sup>
Immunity to irradiated electromagnetic fields	10V/m 26-1000MHz (EN61000-4-3)	Min./Max. cable cross-section area	
Electrostatic discharges	15kV (EN61000-4-2)	Min./Max. screws tightening torque	2 Nm / 6 Nm
Radio frequency emissions	according to CISPR 14 and CISPR 22	<b>Housing</b>	
		Dimensions	162.5 x 90 x 63 mm
		Material	ABS, NORYL, PC self-extinguishing: UL 94 V-0
		<b>Mounting</b>	DIN-rail and wall
		<b>Degree of protection</b>	Front: IP40 Connections: IP20
		<b>Weight</b>	800 g approx. (packing included)

## Function description

### Input and output scaling capability

Working examples of the analogue output (Y) versus the input variable (x) - (input/output scaling possibilities).

**Figure A**

The sign of measured quantity and output quantity remains the same. The output quantity is proportional to the measured quantity.

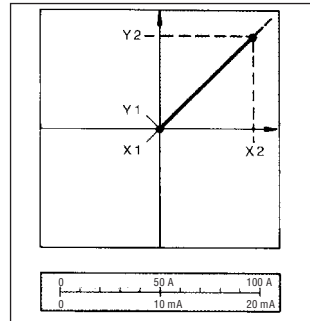

**Figure B**

The sign of measured quantity and output quantity remains the same. With the measured quantity being zero, the output quantity already has the value  $Y_1 = 0.2 Y_2$ . Live zero output.

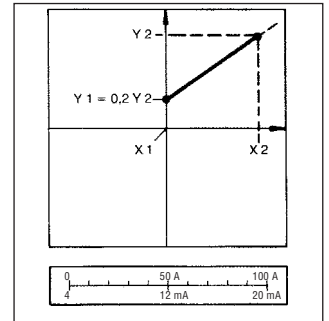

**Figure C**

The sign of measured quantity and output quantity remains the same. On the range  $X_0...X_1$ , the output quantity is zero. The range  $X_1...X_2$  is delineated on the entire output range  $Y_0=Y_1...Y_2$  and thus presented in strongly expanded form.

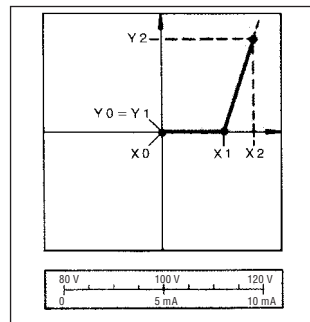

## Mode of Operation

### Waveform of the signals that can be measured

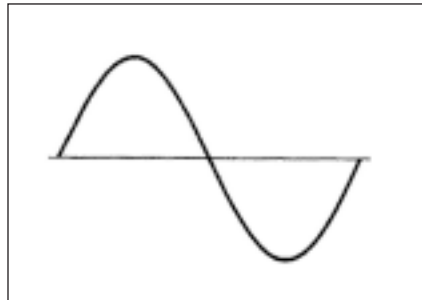

**Figure D**

**Sine wave, undistorted**

Fundamental content 100%  
 Harmonic content 0%  
 $A_{rms} = 1.1107 | \bar{A} |$

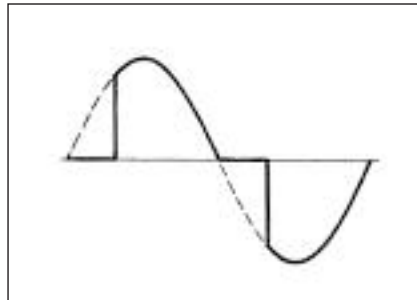

**Figure E**

**Sine wave, indented**

Fundamental content 10...100%  
 Harmonic contents 0...90%  
 Frequency spectrum: 3rd to the 16th harmonic  
 Additional error: <1% rdg

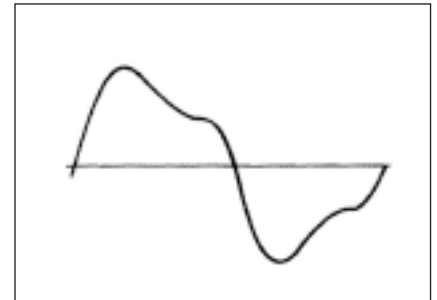

**Figure F**

**Sine wave, distorted**

Fundamental content 70...90%  
 Harmonic content 10...30%  
 Frequency spectrum: 3rd to the 16th harmonic  
 Additional error: <0.5% rdg

## Harmonic distortion analysis

<b>Anaysis principle</b>	FFT	<b>Read-out</b>	THD (AL2), THD (AL3)
<b>Harmonic measurement</b>		<b>System</b>	THD %
Current	Up to the 7 <sup>th</sup> harmonic	The harmonic distortion can be measured in 3-wire or 4-wire systems.	
Voltage	Up to the 7 <sup>th</sup> harmonic		
<b>Type of harmonics</b>	THD (VL1), THD (VL2), THD (VL3), THD (AL1)		

## Display pages

### Variables that can be displayed

No	1 <sup>st</sup> variable	2 <sup>nd</sup> variable	3 <sup>rd</sup> variable	4 <sup>th</sup> variable	Notes
1	W sys	PF sys	Var sys		sys = system
2	W dmd	Hz	VA dmd		dmd = demand (integration time from 1 to 30 minutes)
3	V <sub>L1</sub> THD	V <sub>L2</sub> THD	V <sub>L3</sub> THD		THD = tot. harmonic distortion
4	A <sub>L1</sub> THD	A <sub>L2</sub> THD	A <sub>L3</sub> THD		THD = tot. harmonic distortion
5	kWh				total energy
6	kvarh				total energy
7	kWh				partial energy
8	kvarh				partial energy
9	V <sub>L1</sub>	V <sub>L2</sub>	V <sub>L3</sub>	V <sub>L-L</sub> sys	sys = system
10	A <sub>L1</sub>	A <sub>L2</sub>	A <sub>L3</sub>	Err	Err = in case of negative power
11a	W dmd MAX	VA dmd MAX			Only version 1-5A, dmd = demand
11b	A <sub>L1</sub> MAX	A <sub>L2</sub> MAX	A <sub>L3</sub> MAX		Only version 90A
12	W <sub>L1</sub>	W <sub>L2</sub>	W <sub>L3</sub>	W sys	sys = system
13	VA <sub>L1</sub>	VA <sub>L2</sub>	VA <sub>L3</sub>	VA sys	The system value remains always 0 if the neutral is not connected
14	Var <sub>L1</sub>	Var <sub>L2</sub>	Var <sub>L3</sub>	Var sys	
15	PF <sub>L1</sub>	PF <sub>L2</sub>	PF <sub>L3</sub>	PF sys	

### Used calculation formulas

#### Phase variables

Instantaneous effective voltage

$$V_{IN} = \sqrt{\frac{1}{n} \cdot \sum_1^n (V_{IN})_i^2}$$

Instantaneous active power

$$W_1 = \frac{1}{n} \cdot \sum_1^n (V_{IN})_i \cdot (A_1)_i$$

Instantaneous power factor

$$\cos\phi_1 = \frac{W_1}{VA_1} \quad (\text{TPF})$$

Instantaneous effective current

$$A_1 = \sqrt{\frac{1}{n} \cdot \sum_1^n (A_1)_i^2}$$

Instantaneous apparent power

$$VA_1 = V_{IN} \cdot A_1$$

Instantaneous reactive power

$$VAR_1 = \sqrt{(VA_1)^2 - (W_1)^2}$$

#### System variables

Equivalent system voltage

$$V_{\Sigma} = \frac{V_1 + V_2 + V_3}{3} \cdot \sqrt{3}$$

System reactive power

$$VAR_{\Sigma} = (VAR_1 + VAR_2 + VAR_3)$$

System active power

$$W_{\Sigma} = W_1 + W_2 + W_3$$

System apparent power

$$VA_{\Sigma} = \sqrt{W_{\Sigma}^2 + VAR_{\Sigma}^2}$$

System power factor

$$\cos\phi_{\Sigma} = \frac{W_{\Sigma}}{VA_{\Sigma}} \quad (\text{TPF})$$

Total harmonic distortion

$$THD_i = \frac{\sqrt{\sum_{n=2}^{\infty} T_n^2}}{T_1}$$

Note:

i = phase (L1, L2 or L3)

T = variable (V or I)

n = harmonic order

#### Consumption recording

$$kWh_i = \int_{t_1}^{t_2} P_i(t) dt \approx \Delta t \sum_{n_1}^{n_2} P_{i,n}$$

$$kVarh_i = \int_{t_1}^{t_2} Q_i(t) dt \approx \Delta t \sum_{n_1}^{n_2} Q_{i,n}$$

Note:

i = phase (L1, L2 or L3)

P = active power

Q = reactive power

t<sub>1</sub>, t<sub>2</sub> = starting and ending time points of consumption recording

n = time unit

Δt = time interval of consumption recording

n<sub>1</sub>, n<sub>2</sub> = starting and ending discrete time points of consumption recording

## List of the of the variables that can be connected to the analogue and alarm output

N°	Variable	Notes	N°	Variable	Notes
1	V sys	sys = system	6	THD-V	Max. THD value among the three phases
2	W sys	sys = system	7	THD-A	Max. THD value among the three phases
3	var sys	sys = system	8	VA dmd	Power demand in the selected
4	VA sys	sys = system	9	W dmd	integration time
5	PF sys	sys = system	10	ASY	Phase asymmetry



## Available models

Type	Inputs	Power supply	Ordering code
WM22-DIN AV9.3.X.	400V <sub>L-L</sub> , 20(90)A	Self power supply	AF2100
WM22-DIN AV8.3.X.	208V <sub>L-L</sub> , 20(90)A	Self power-supply	AF2101
WM22-DIN AV2.3.D.	220V <sub>L-L</sub> , 20(90)A	Self power-supply	AF2144
WM22-DIN AV1.3.D.	400V <sub>L-L</sub> , 20(90)A	230VAC, 50-60Hz	AF2102
WM22-DIN AV0.3.D.	208V <sub>L-L</sub> , 20(90)A	230VAC, 50-60Hz	AF2103
WM22-DIN AV3.3.D.	660V <sub>L-L</sub> , 20(90)A	230VAC, 50-60Hz	AF2104
WM22-DIN AV1.3.C.	400V <sub>L-L</sub> , 20(90)A	115VAC, 50-60Hz	AF2105
WM22-DIN AV0.3.C.	208V <sub>L-L</sub> , 20(90)A	115VAC, 50-60Hz	AF2106
WM22-DIN AV3.3.C.	660V <sub>L-L</sub> , 20(90)A	115VAC, 50-60Hz	AF2107
WM22-DIN AV1.3.B.	400V <sub>L-L</sub> , 20(90)A	48VAC, 50-60Hz	AF2108
WM22-DIN AV0.3.B.	208V <sub>L-L</sub> , 20(90)A	48VAC, 50-60Hz	AF2109
WM22-DIN AV3.3.B.	660V <sub>L-L</sub> , 20(90)A	48VAC, 50-60Hz	AF2110
WM22-DIN AV1.3.A.	400V <sub>L-L</sub> , 20(90)A	24VAC, 50-60Hz	AF2111
WM22-DIN AV0.3.A.	208V <sub>L-L</sub> , 20(90)A	24VAC, 50-60Hz	AF2112
WM22-DIN AV3.3.A.	660V <sub>L-L</sub> , 20(90)A	24VAC, 50-60Hz	AF2113
WM22-DIN AV5.3.D.	400V <sub>L-L</sub> , 5(10)A	230VAC, 50-60Hz	AF2114
WM22-DIN AV4.3.D.	208V <sub>L-L</sub> , 5(10)A	230VAC, 50-60Hz	AF2115
WM22-DIN AV7.3.D.	660V <sub>L-L</sub> , 5(10)A	230VAC, 50-60Hz	AF2116
WM22-DIN AV5.3.C.	400V <sub>L-L</sub> , 5(10)A	115VAC, 50-60Hz	AF2117
WM22-DIN AV4.3.C.	208V <sub>L-L</sub> , 5(10)A	115VAC, 50-60Hz	AF2118
WM22-DIN AV7.3.C.	660V <sub>L-L</sub> , 5(10)A	115VAC, 50-60Hz	AF2119
WM22-DIN AV5.3.B.	400V <sub>L-L</sub> , 5(10)A	48VAC, 50-60Hz	AF2120
WM22-DIN AV4.3.B.	208V <sub>L-L</sub> , 5(10)A	48VAC, 50-60Hz	AF2121
WM22-DIN AV7.3.B.	660V <sub>L-L</sub> , 5(10)A	48VAC, 50-60Hz	AF2122
WM22-DIN AV5.3.A.	400V <sub>L-L</sub> , 5(10)A	24VAC, 50-60Hz	AF2123
WM22-DIN AV4.3.A.	208V <sub>L-L</sub> , 5(10)A	24VAC, 50-60Hz	AF2124
WM22-DIN AV7.3.A.	660V <sub>L-L</sub> , 5(10)A	24VAC, 50-60Hz	AF2125
WM22-DIN AV6.3.D.	100V <sub>L-L</sub> , 5(10)A	230VAC, 50-60Hz	AF2126
WM22-DIN AV6.3.C.	100V <sub>L-L</sub> , 5(10)A	115VAC, 50-60Hz	AF2127
WM22-DIN AV6.3.B.	100V <sub>L-L</sub> , 5(10)A	48VAC, 50-60Hz	AF2128
WM22-DIN AV6.3.A.	100V <sub>L-L</sub> , 5(10)A	24VAC, 50-60Hz	AF2129
WM22-DIN AV1.3.4 / [5]	400V <sub>L-L</sub> , 20(90)A	18-60VDC [77-143VDC]	AF2130 [AF2137]
WM22-DIN AV0.3.4 / [5]	208V <sub>L-L</sub> , 20(90)A	18-60VDC [77-143VDC]	AF2131 [AF2138]
WM22-DIN AV3.3.4 / [5]	660V <sub>L-L</sub> , 20(90)A	18-60VDC [77-143VDC]	AF2132 [AF2139]
WM22-DIN AV5.3.4 / [5]	400V <sub>L-L</sub> , 5(10)A	18-60VDC [77-143VDC]	AF2133 [AF2140]
WM22-DIN AV4.3.4 / [5]	208V <sub>L-L</sub> , 5(10)A	18-60VDC [77-143VDC]	AF2134 [AF2141]
WM22-DIN AV7.3.4 / [5]	660V <sub>L-L</sub> , 5(10)A	18-60VDC [77-143VDC]	AF2135 [AF2142]
WM22-DIN AV6.3.4 / [5]	100V <sub>L-L</sub> , 5(10)A	18-60VDC [77-143VDC]	AF2136 [AF2143]

## Available modules

Type	Channels	Code	Type	Channels	Code
Open collector output	2	A02900	0-10VDC Analogue Output	1	A02921
0-20mADC analogue output	1	A02920	RS485 Serial Output	1	AR2950
Relay + open c. output	2	A02910			

## Possible module combinations

Power supply	Self p.s.		Auxiliary p.s.		Power supply	Self p.s.		Auxiliary p.s.	
	Slot A	Slot B	Slot A	Slot B		Slot A	Slot B	Slot A	Slot B
Basic unit					Basic unit				
Open collector output	●		●		Analogue output		●(*)		●
Relay + open c. output	●		●		RS485 Serial Output		●(*)		●

(\*) AV2 only

## Wiring diagrams

### 20(90)A model: three-phase unbalanced load

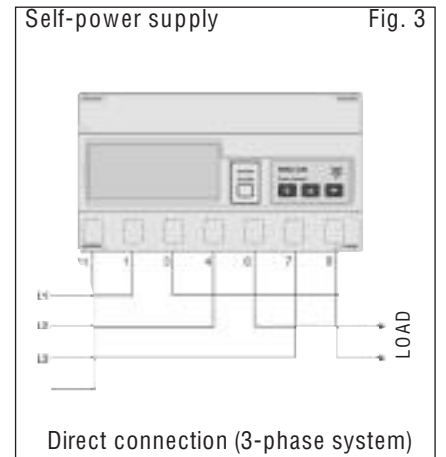
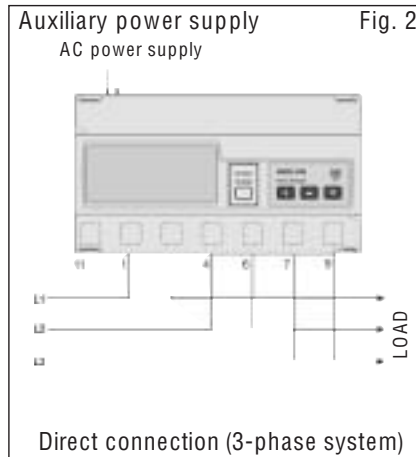
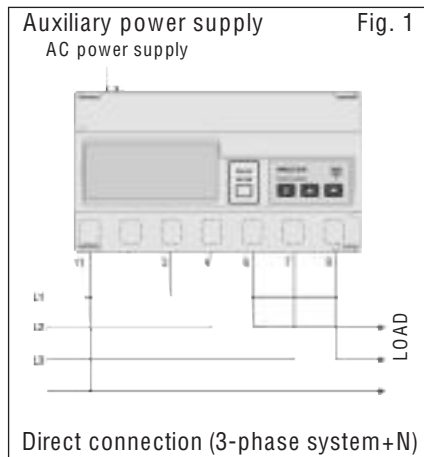

### 20(90)A model: three-phase unbalanced load

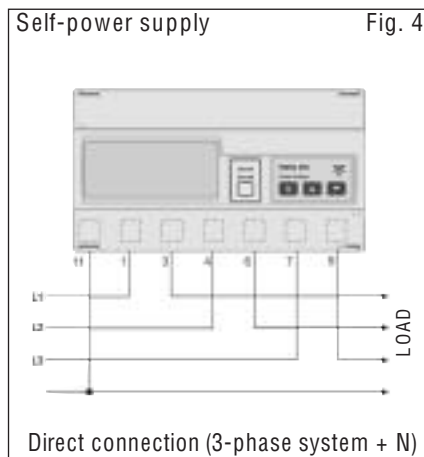

### 5(10)A model: three-phase unbalanced load

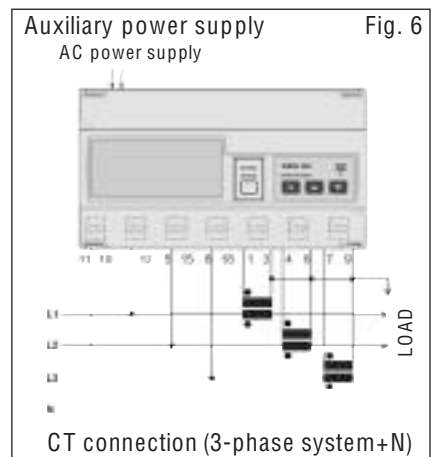
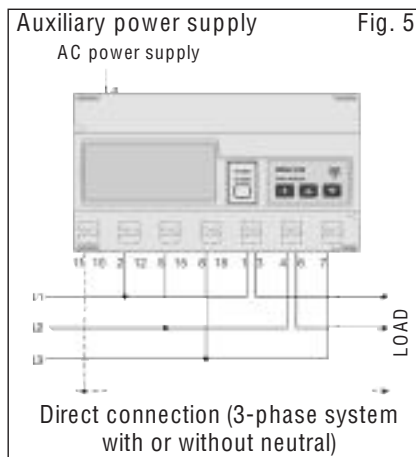

### 5(10)A model: three-phase unbalanced load

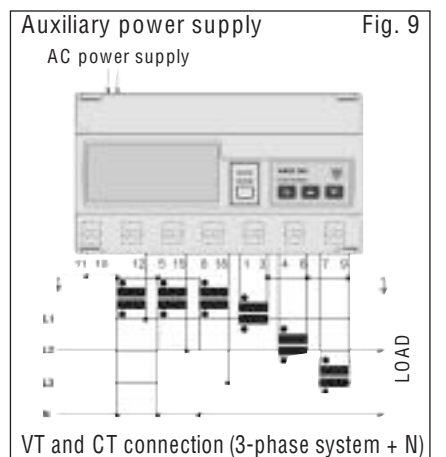
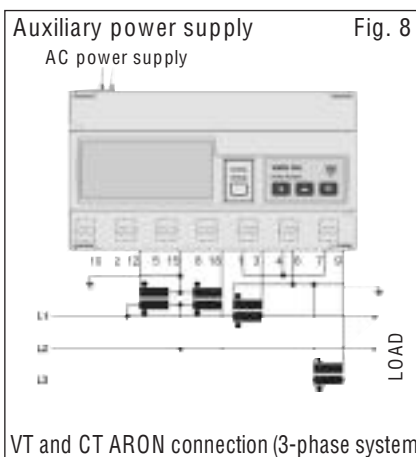
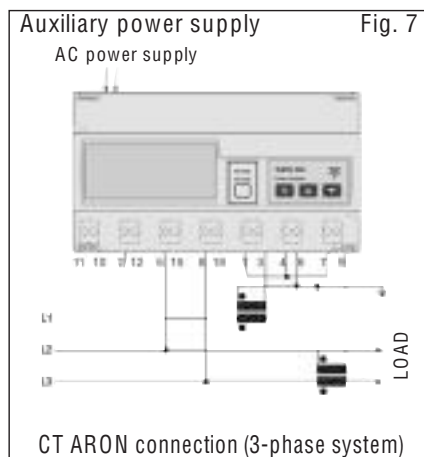



## Wiring diagrams (optional modules)

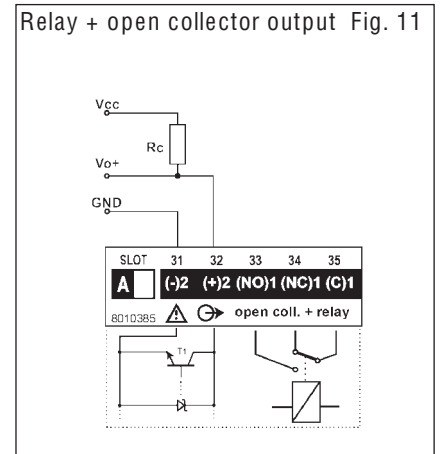
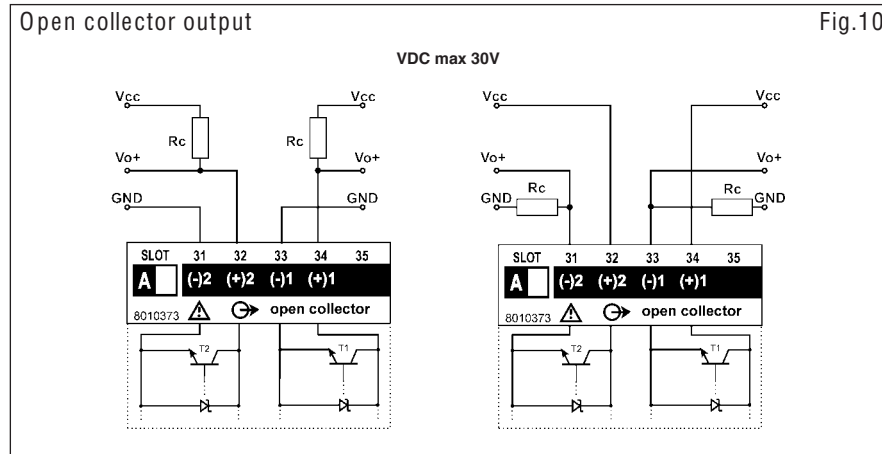

Only open collector outputs: the grounds of the outputs are separated, and therefore it's possible to carry out, for the same module, two different connections. The load resistance (Rc) must be designed so that the closed contact current is lower than 100mA; the VDC voltage must be lower than or equal to 30V. VDC: power supply voltage output. Vo+: positive output contact (open collector transistor). GND: ground output contact (open collector transistor).

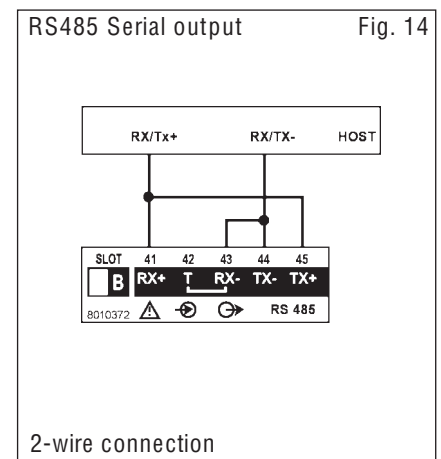
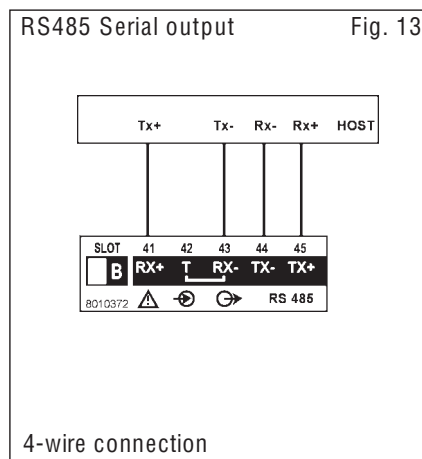
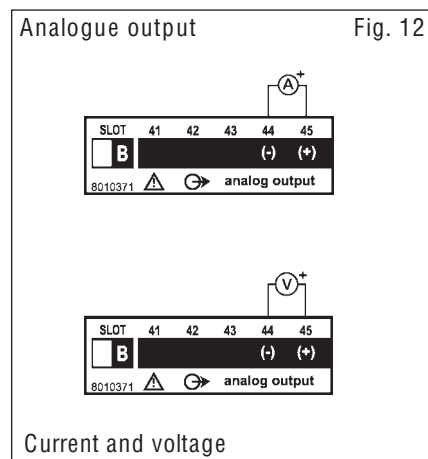

## Front panel description

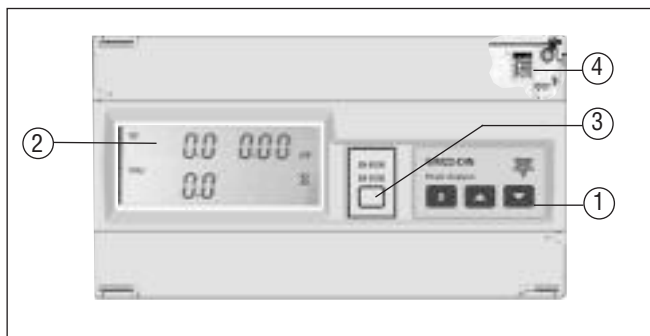

Keys for:  
 - value programming;  
 - function selection;  
 - displaying the measuring pages.

**1. Key-pad**  
 To program configuration parameters and to display variables.  
 S  
 S-key to enter programming and confirm selections;

**2. Display**  
 LCD with alphanumeric indications to:  
 - display configuration parameters;  
 - display all the measured variables.

**3. Removable label**  
 Label to write the instrument ID number.

**4. Hidden dip-switch**  
 Enable/ disable the access to the programming procedure.

## Dimensions and panel cut-out

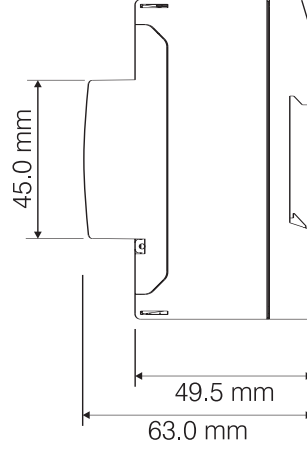
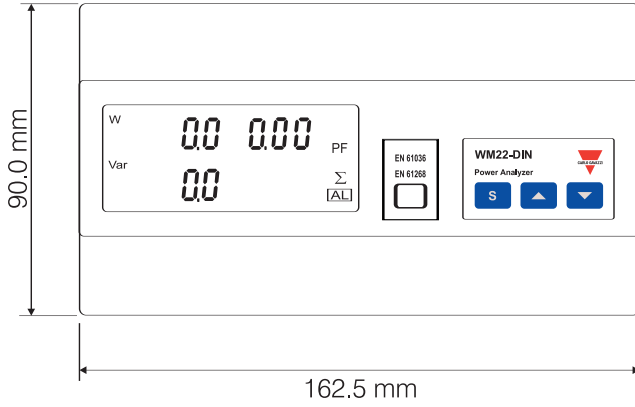

## Terminal boards

### Analogue output module

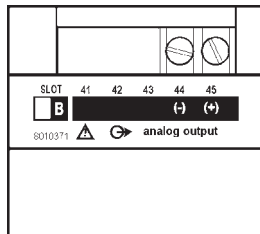

**AO 2920: 0-20 mA**  
**AO 2921: 0-10 V**

### Dual output open collector module

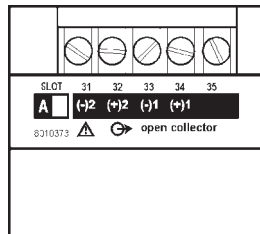

**AO 2900**

### Relay output module + open collector output

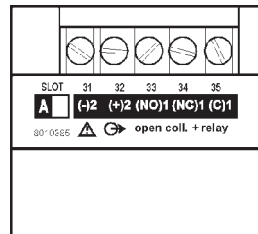

**AO 2910**

### RS485 serial output module

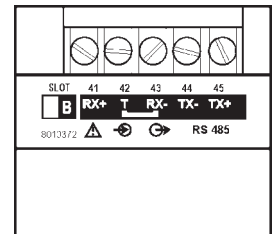

**AR 2950**