

# Si-82 PACK 1

## CENTRIFUGAL PUMP



The Si-82 pump is designed to be easily installed whatever the layout of the premises. Capable of evacuating up to 500 l/h, the Si-82 pump is suitable for air conditioning units and industrial refrigeration displays. Strong, the Si-82 tolerates charged, high temperature and acidic condensates (pH>2.5) produced by gas condensing boilers.

### BENEFITS

#### ● High performance

- Can discharge condensates **up to 5m**
- **Up to 500 l/h**, for shorter running time
- **Low sound level** – quiet operation

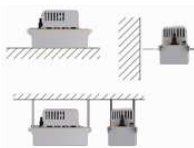

#### ● Installation in any place

Pump can be floor mounted, attached on a wall or hanging from a ceiling.



#### ● Versatile

Easily removable tank and reversible pump, to allow mounting rather on the left or on the right of the application and choosing the side of the water exit.



#### ● Easy electrical connection

New plug-in power cord to facilitate installation and maintenance.



#### ● Easy hydraulic connection

- New quarter turn easily removable check valve, designed to facilitate  $\text{Ø}_{\text{int}} 10 \text{ mm}$  (3/8") hose plug in
- 4 inlet holes  $\text{Ø} 30 \text{ mm}$  ( $1 \text{''} \frac{3}{16}$ )

#### ● High resistance

- **Oil and acid resistant** float
- Mechanical structure **resistant to shocks**

### KIT CONTENTS



- One-piece centrifugal pump with tank (2L).
- Integrated barb end check valve  $\text{Ø}_{\text{ext}} 10 \text{ mm}$  (3/8").
- Plug-in power (1.5m, **bare ends**) & safety switch cord, (1.5 m, bare ends)
- $\text{Ø}_{\text{ext}} 10 \text{ mm}$  (3/8") to  $\text{Ø}_{\text{ext}} 6 \text{ mm}$  (1/4") straight connector
- 2 screws + 2 plugs

## APPLICATIONS

- Column air conditioning units • Multi cassettes • Ducted units
- Condensing boilers • High efficiency gas furnace
- Refrigerating display cabinets • Evaporators

TECHNICAL CHARACTERISTICS	
Max. flow rate	500 l/h
Max. discharge head	5.0m
Max pressure	5.4 m (flowrate=0)
Sound level in application at 1m(3.3ft): ≤ 45 dBA (Measured in Sauermann acoustic lab, pump operating with water)	
Mains supply	230V~ 50Hz - 70 W – 0.67A
Detection levels	On : 53mm, Off : 42mm, Alarm : 64mm
Safety switch	NC 4 A resistive – 250V
Max. condensate temperature	65°C, 80°C in short peak
Max. condensate acidity	pH > 2.5 (Gas condensing boilers)
Thermal protection (overheating)	105°C (auto-reset)
Intermittent operation cycle	30%: 3s ON – 7s OFF
Protection	IP20
Safety standards	CE
RoHS directive	Compliant
DEEE directive	Compliant
Weight (including box)	2.5 kg
Packaging	4 pcs: L400xW300xH200 mm
Pallet quantity	64 pieces in Palbox (EUR size)

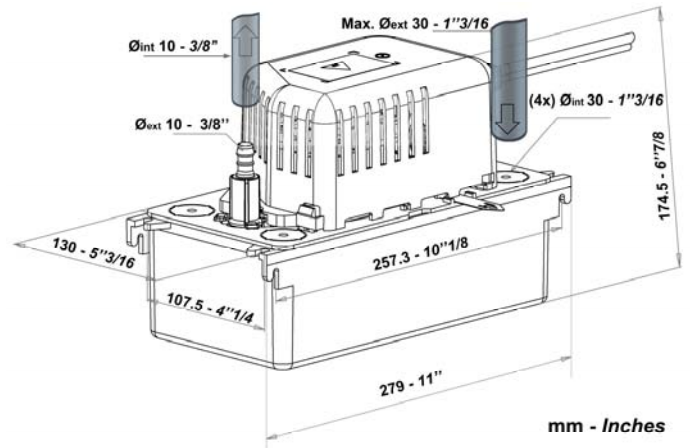

ACTUAL FLOW RATES (l/h)				
Vertical Discharge head	Total tube length (Øint 10 mm, 3/8")			
	5 m	10 m	20 m	30 m
1 m	380	300	240	190
2 m	310	260	200	150
3 m	240	200	145	110
4 m	150	130	80	60
5 m	30	20	0	0

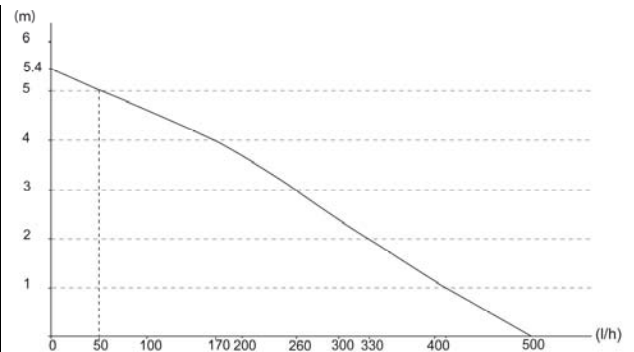

## RECOMMENDED ACCESSORIES

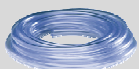

**ACC 00125, ACC 00126**  
Hose Øint 10 mm (3/8")  
ACC 00125 : 25 m roll  
ACC 00126 : reinforcing 25 m roll



**ACC 00801**  
Replacement check valve  
Øext 10 mm (3/8")



**ACC 02040**  
Inlet adaptor  
Øint 24/25 - 32 - 40mm  
(Øint 1" - 1 1/4 - 1 1/2)